

Review of ICT

MATT CANTERFORD- ASSISTANT DIRECTOR, CHIEF TECHNOLOGY OFFICER

Lorraine Rossati



Title: Executive Member - Culture, Leisure and Information Technology

Party: Labour & Co-operative

Ward: Old Town

Other councillors representing this Ward:

- Jim Brown
- John Duncan

Jeannette Thomas



Title: Deputy Leader of the Council - Executive Member - Housing and Housing Development

Party: Labour & Co-operative

Ward: Pin Green

Other councillors representing this Ward:

- Lisa Martin-Haugh
- Maureen McKay



Planning & Growth
Cllr Vicky Glover-Ward



Corporate Services
Cllr Joseph Dumont



Leader of the Council
Cllr Ben Crystall

ICT Joint Committee

- Helen Standen - Interim Chief Executive
- Clare Fletcher - Strategic Director (CFO)
- Matt Partridge - Chief Executive
- Matt Canterford - Assistant Director and Chief Technology Officer

Conor McGrath



Title: Cabinet Member - Stronger Communities

Party: Labour & Co-operative

Ward: Bedwell

Other councillors representing this Ward:

- Nazmin Chowdhury
- Ellie Plater

Joint ICT Service Potted History

- 2012 - Joint ICT Service was set up
- June 2019 - Review of Shared IT Services complete by 31 Ten
- 2020 - Covid 19 Demand on the IT Services increased by 350%
- February 2022 - Review of Shared IT Services – Feb 2022 complete by Socitm Advisory

Technical Debt

- Windows 2008 servers decommissioned
- Windows 7 migration to Windows 10
- New Virtual Desktop Infrastructure
- New Microwave link
- M365 rollout
- New Firewall
- New Pure Storage
- Servers Compute Upgrade
- Wi-Fi and Network Upgrade
- Telephony - Upgrade

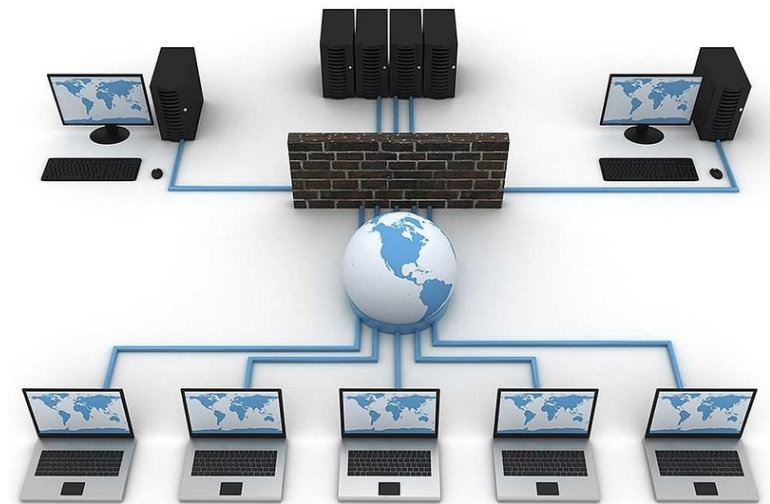
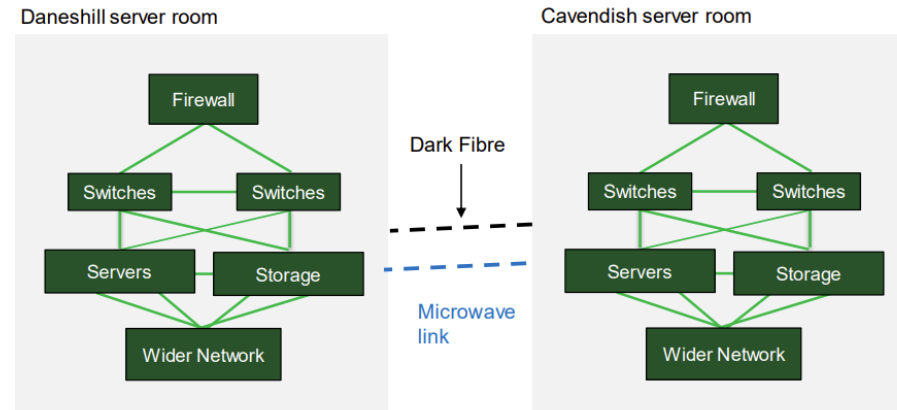

Joint IT Service Operating Model

- East Herts District Council and Stevenage Borough Council commissioned SOCITIM Advisory to design the Future Operating Model for the Joint IT Service
- The model has the capacity and capabilities to deliver Joint IT Strategy, Council Plans, Day-to-day operations and ongoing system maintenance and development, Support in refreshing their core IT services to support current and future development, as well as transformation projects
- In October 2023, the Joint Information Communication Technology Committee agreed to invest £629,795 over the next two years and aim to fill all roles in the new structure by March 2026

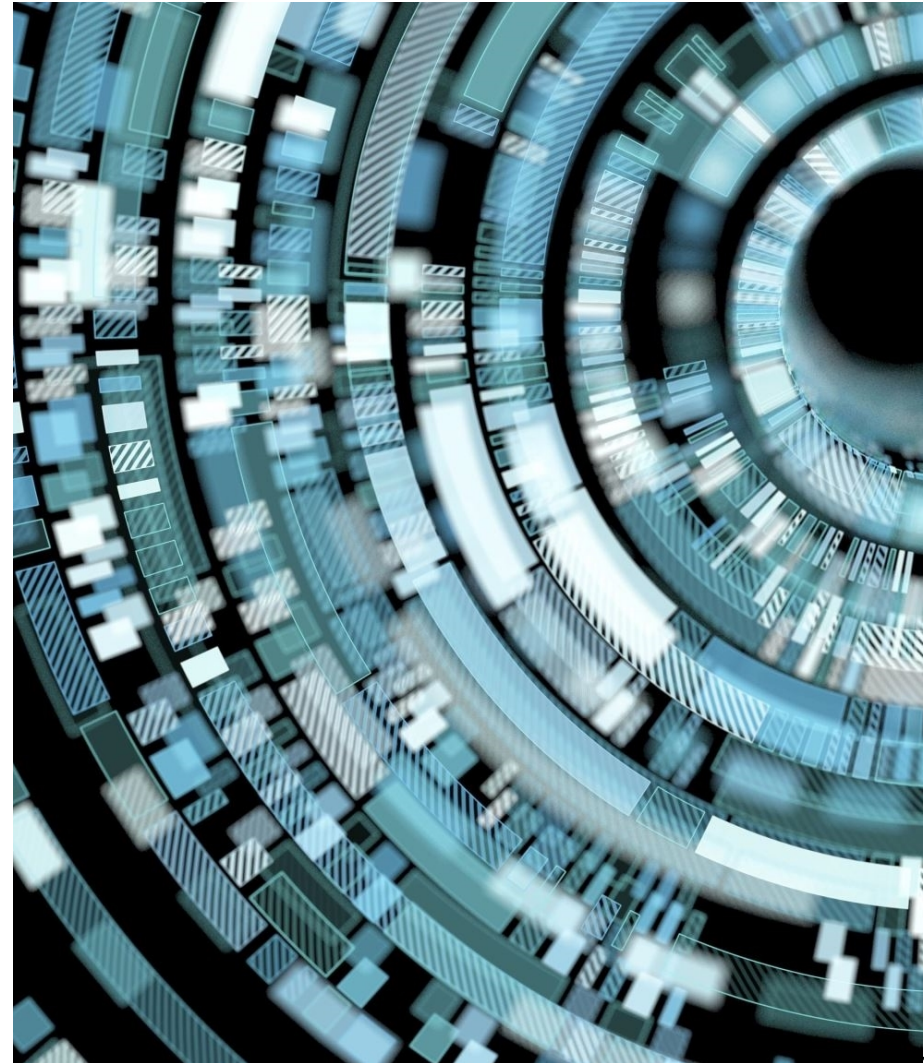

New Structure

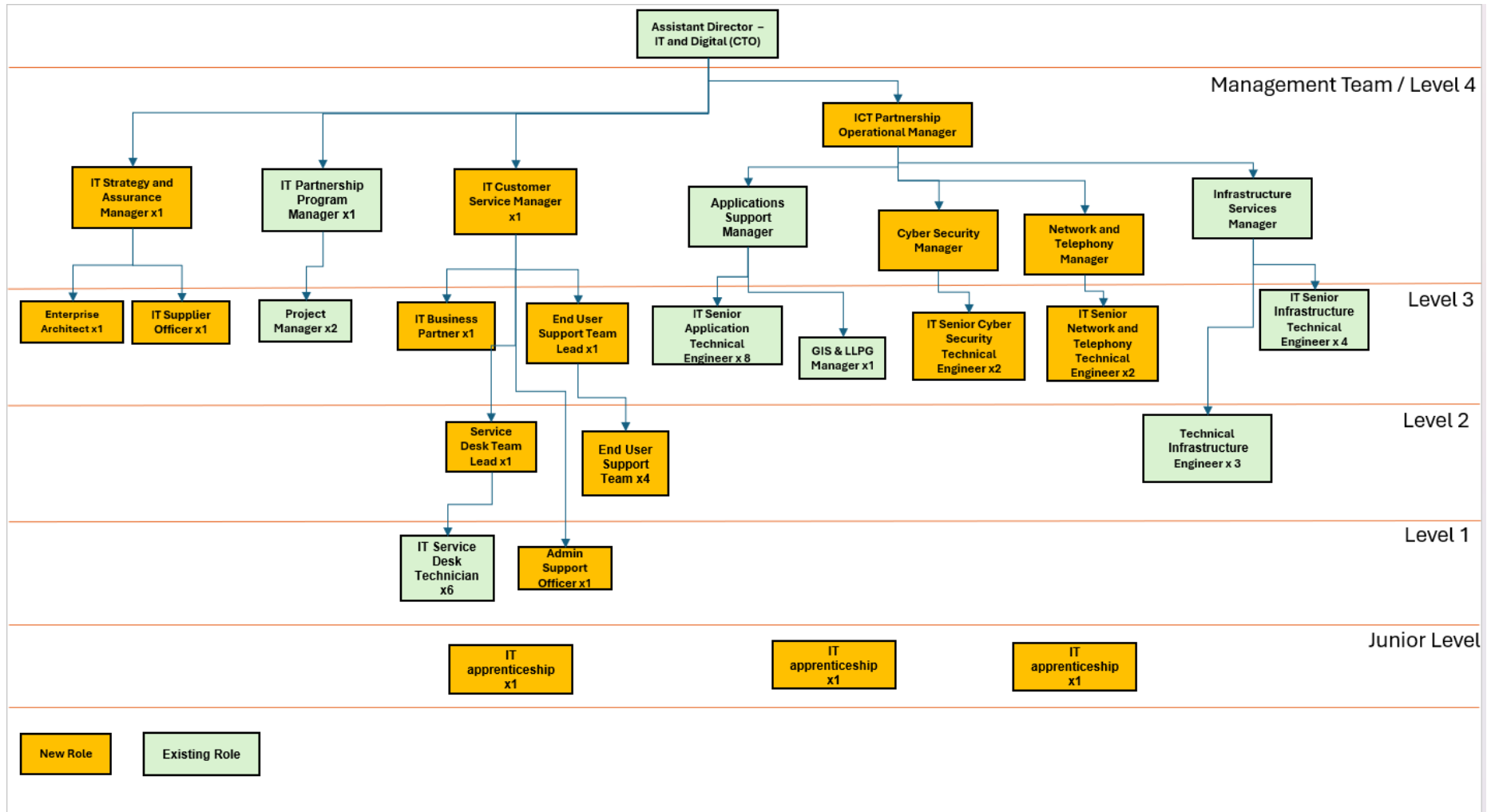

IT Strategy and Assurance

- The IT Strategy and Assurance team oversees strategic alignment and service design capabilities.
- The team leads the governing body that ensures technical decisions match business goals and best practices.
- The team supports the development of strategy and policy, including data engineering and enhanced supplier management capabilities.

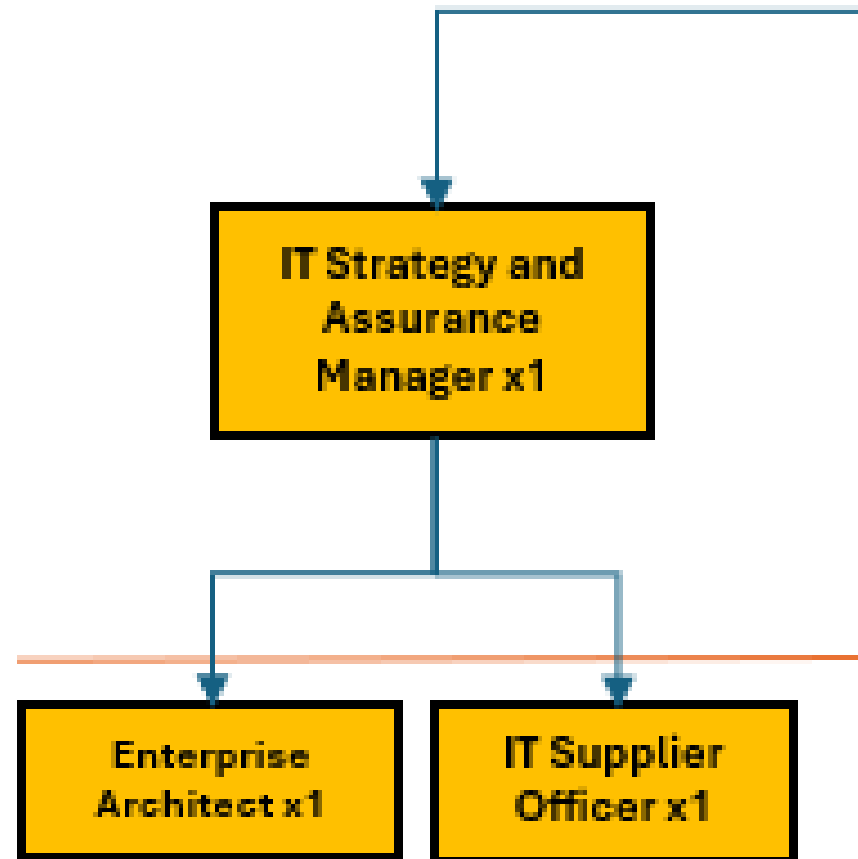

ICT Programme Management Office

- Acts as the central nervous system for IT projects within Stevenage Borough Council and East Herts District Councils.
- Oversees the entire project lifecycle, from initial feasibility studies to implementation and ongoing support.
- Ensures projects are aligned with the overall ICT strategy, resources are effectively allocated, and best practices are followed to deliver successful IT initiatives that drive business value for both councils.

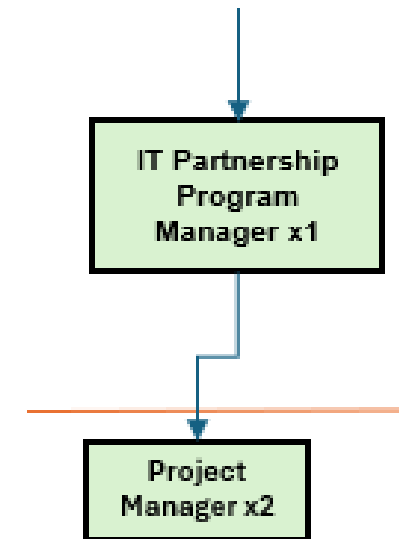

IT Customer Service

- Ensure users receive prompt, professional, and knowledgeable support.
- Build positive and productive relationships with IT users.
- Manage interface between customers and IT Service for efficient and effective operations.

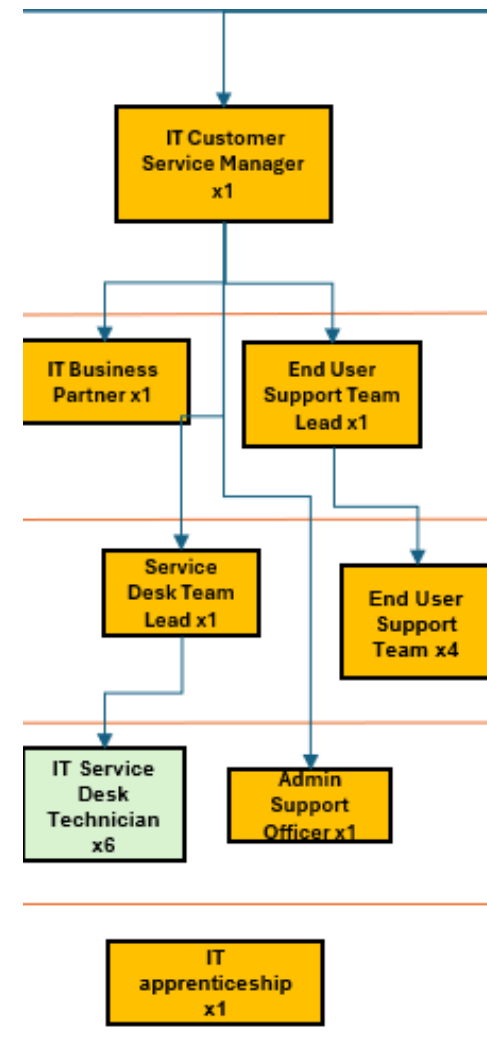

The IT Business Partner

- Acts as a liaison between business units and IT department
- Understands operational and developmental needs of business
- Collaborates with business to determine how IT can support needs
- Evaluates demand, identifies requirements, streamlines areas
- Proactively scans horizon to support council strategies aligned with IT strategy
- Aligns IT strategies with business objectives, identifies opportunities for technological advancements and ensures seamless communication between technical and non-technical stakeholders

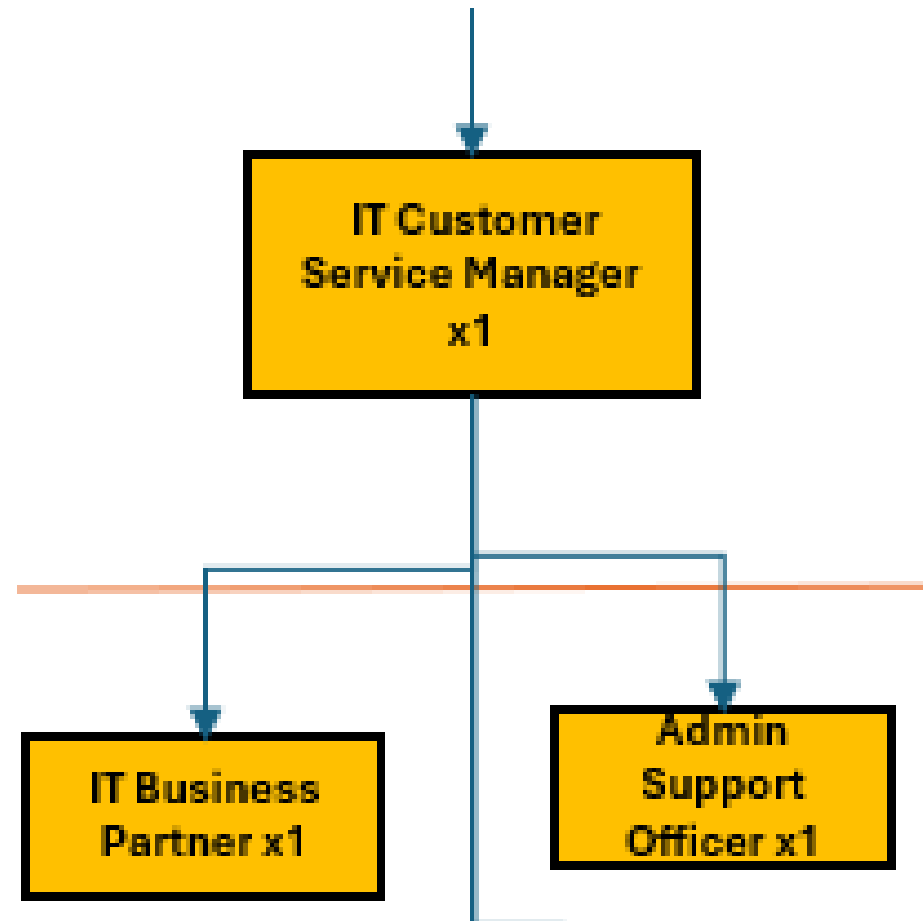

ICT End-User Support Team

- Provides technical assistance and support to end-users
- Ensures technical issues are addressed effectively and promptly
- Delivers high-quality customer service

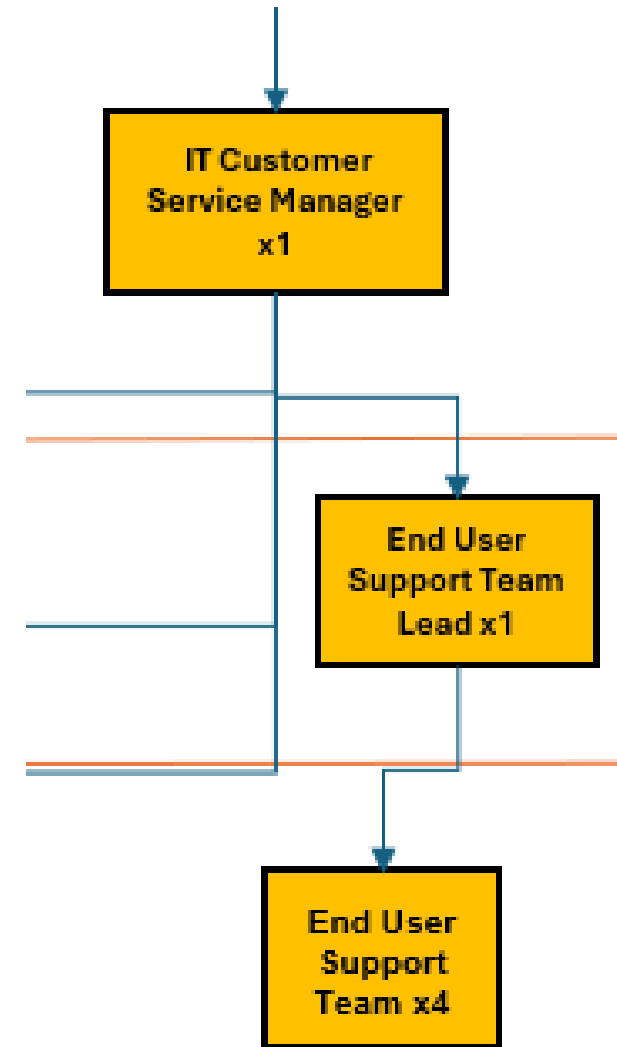

ICT Service Desk

- The ICT Service Desk is the main point of contact for ICT support.
- It resolves user issues and offers technical guidance.
- It serves both Stevenage Borough Council and East Herts District Councils.

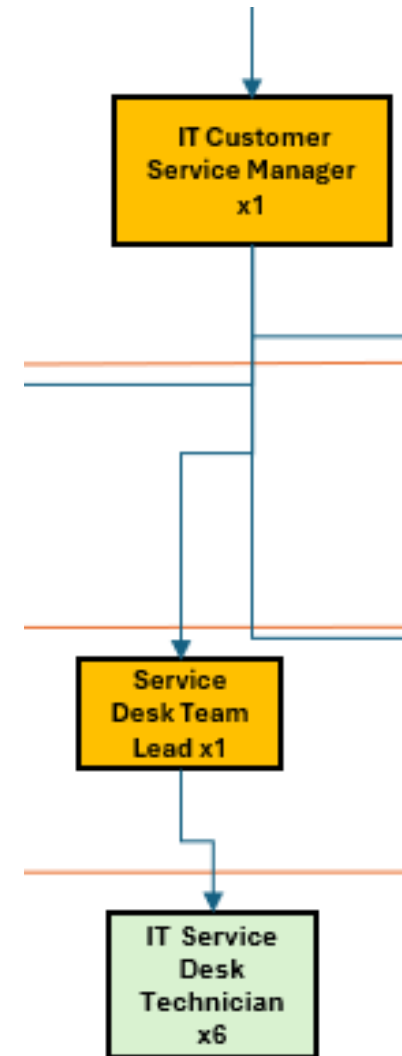

ICT Operations Service

- Applications Support, Cyber Security, Networks and Telephony, and Infrastructure teams
- Ensure availability, security, and performance of IT systems, networks, Telephony, and applications
- Support development and maintenance of IT strategy, policies, procedures, and best practices

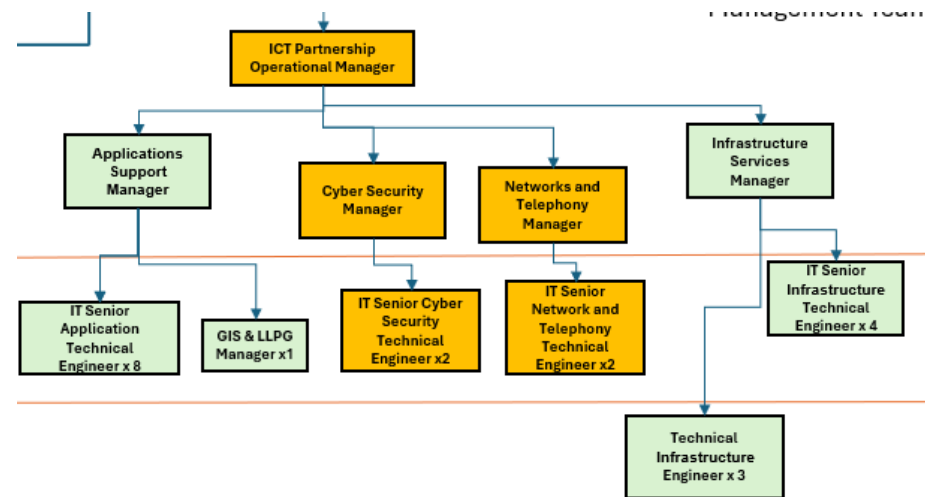

ICT Applications Support

- The Applications Support team provides technical support and maintains software applications.
- The team develops and implements support policies and procedures.
- They troubleshoot and resolve application issues and manage the support process.
- They stay up to date with the latest application technologies and trends.
- The team provides guidance to users on new application features and functionality.
- They work with software suppliers to identify and resolve application bugs.

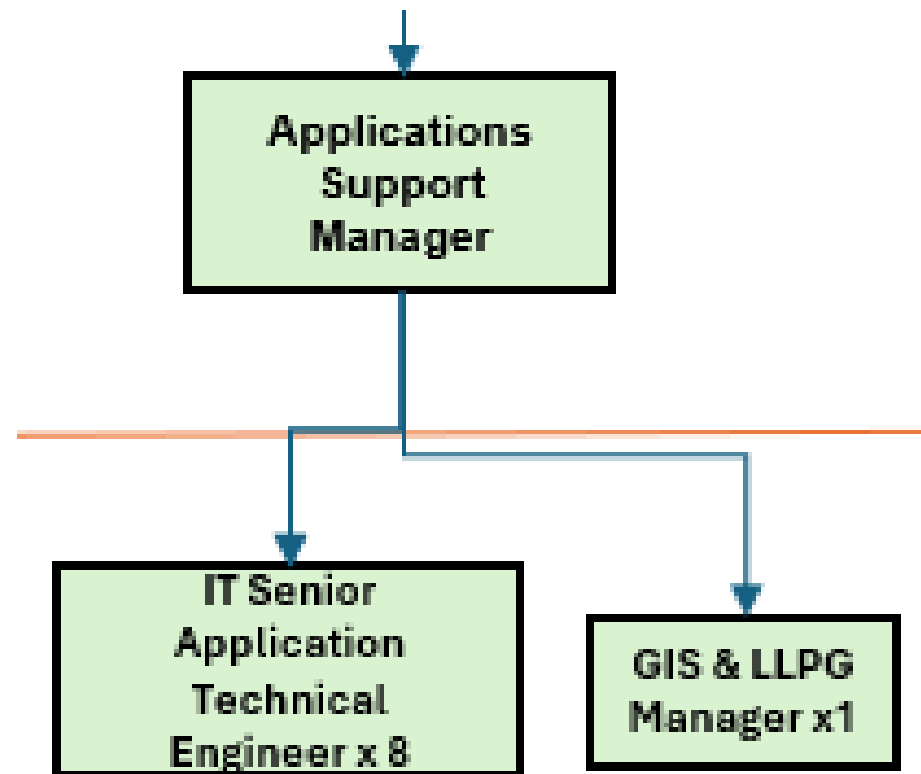

Cyber Security

- Ensuring security of council's IT
- Evaluating new and existing projects for security risks
- Implementing firewalls, data protection controls, patching, encryption, and vulnerability scanning
- Achieving compliance with regulations and standards

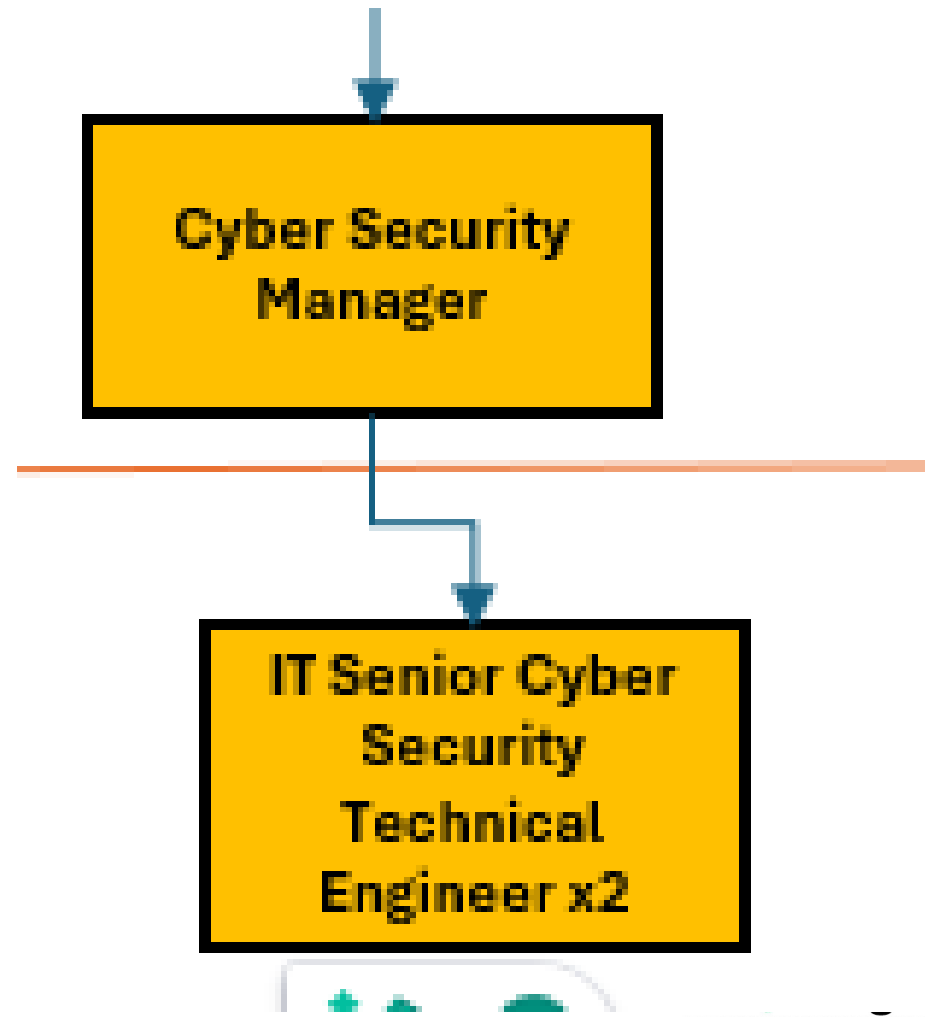

ICT Network and Telephony

- Oversee design, implementation, management and maintenance of network infrastructure and telephony systems.
- Develop and implement network and telephony strategies to support council objectives.
- Monitor network and telephony performance and provide technical support to users.
- Ensure compliance with all relevant network and telephony regulations.

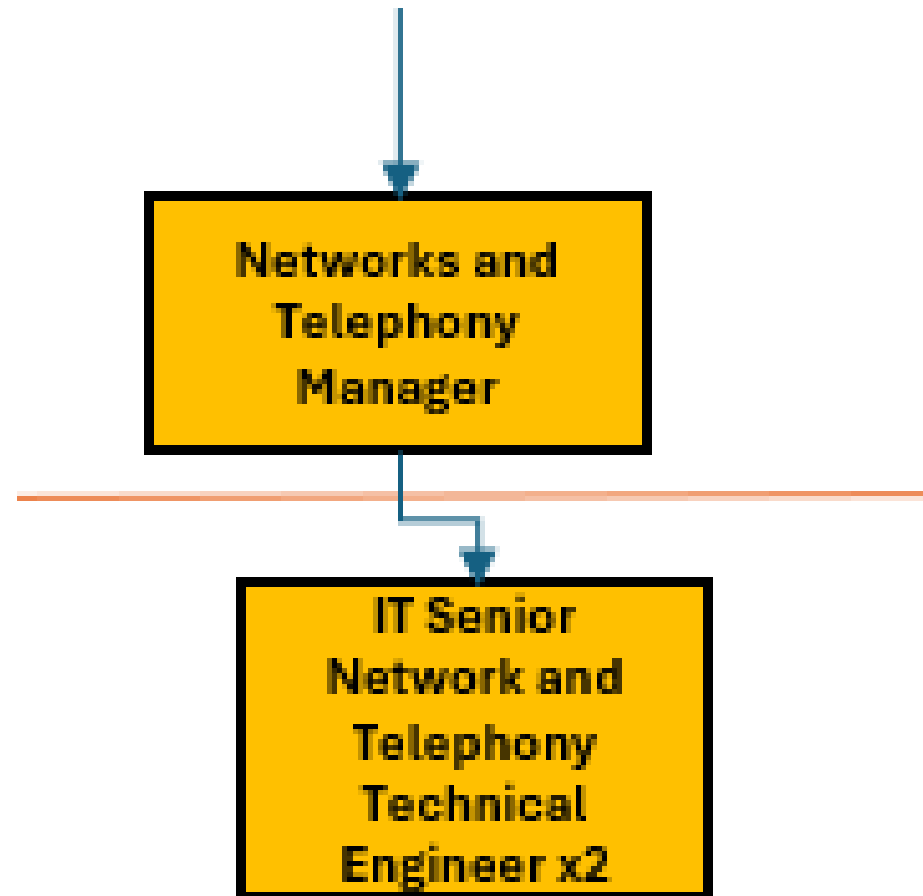

ICT Infrastructure

- The infrastructure team plans, designs, implements, and manages Microsoft products for Stevenage Borough Council and East Herts District Councils.
- They ensure the reliability, security, usability, availability, and performance of the IT infrastructure.
- The team provides support to users, troubleshoots issues, and develops and implements support policies and procedures.

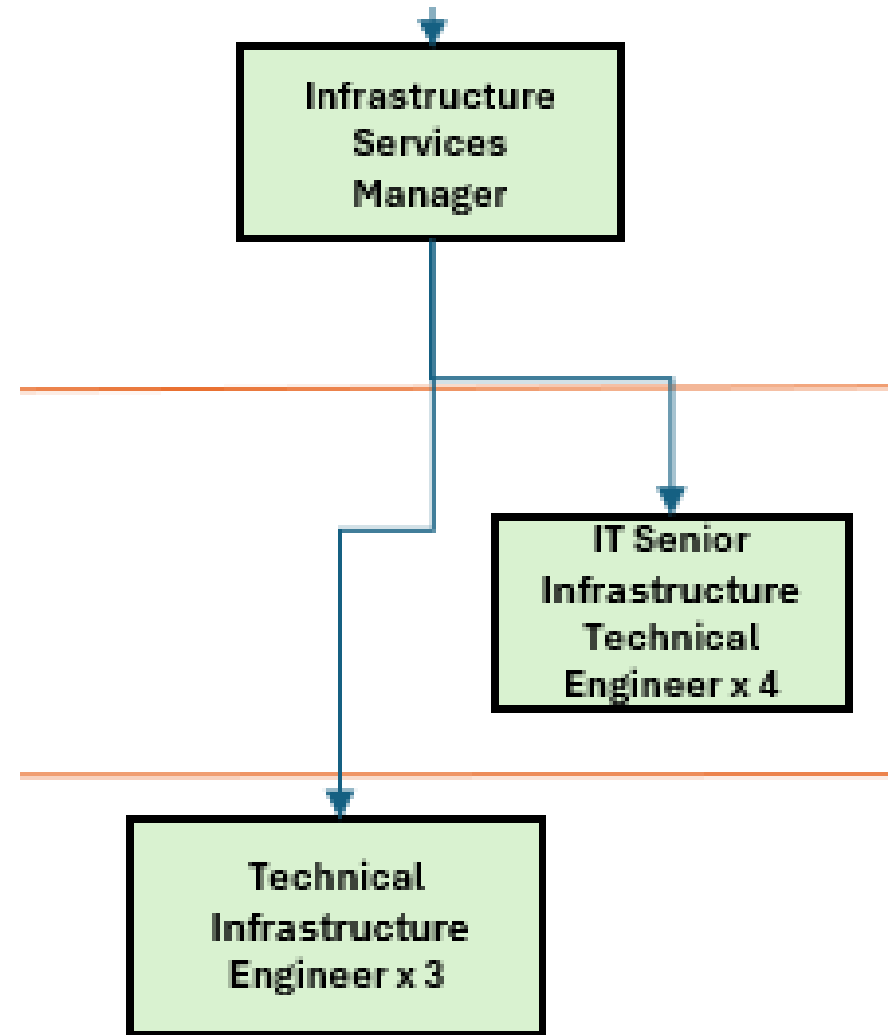

Uptime

Uptime and P1's for IT infrastructure		
2023 / 2024		
	Stevenage	
Apr-23	100%	
May-23	92.30%	17 hours downtime for Widows 7 issue for Housing (150 staff)
Jun-23	100%	
Jul-23	100%	
Aug-23	100%	
Sep-23	100%	
Oct-23	100%	
Nov-23	100%	
Dec-23	100%	
Jan-24	100%	
Feb-24	100%	
Mar-24	100%	
Total	99%	The target is 99%
Uptime and P1's for IT infrastructure.		
2024 / 2025		
	Stevenage	
Apr-24	100%	
May-24	100%	
Jun-24	100%	
Jul-24	100%	
Aug-24	100%	
Total	100%	The target is 99%

ICT Changes

	Achieve a 98% success rate for IT infrastructure change requests.
Apr-24	100%
May-24	100%
Jun-24	100%
Jul-24	100%
Aug-24	100%
Total	100%

	Achieve a 98% success rate for IT Network change requests.
Apr-24	100%
May-24	100%
Jun-24	100%
Jul-24	100%
Aug-24	100%
Total	100%

	Achieve a 98% success rate for application change requests.
Apr-24	100%
May-24	100%
Jun-24	100%
Jul-24	100%
Aug-24	100%
Total	100%

INCIDENTS THAT ARE RESOLVED WITHIN FOUR HOURS

■ Stevenage

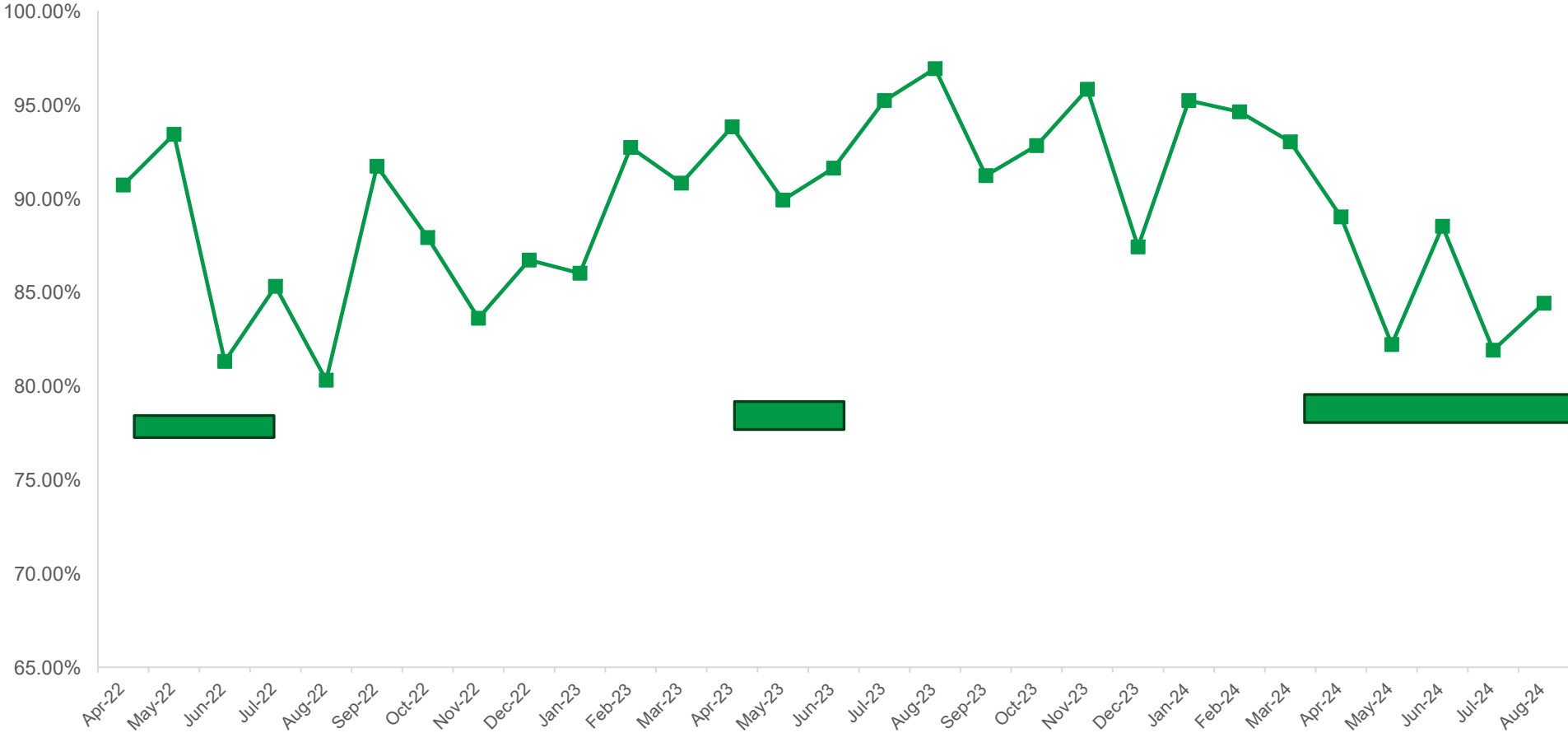

SERVICE REQUESTS MEETING SLA

■ Stevenage

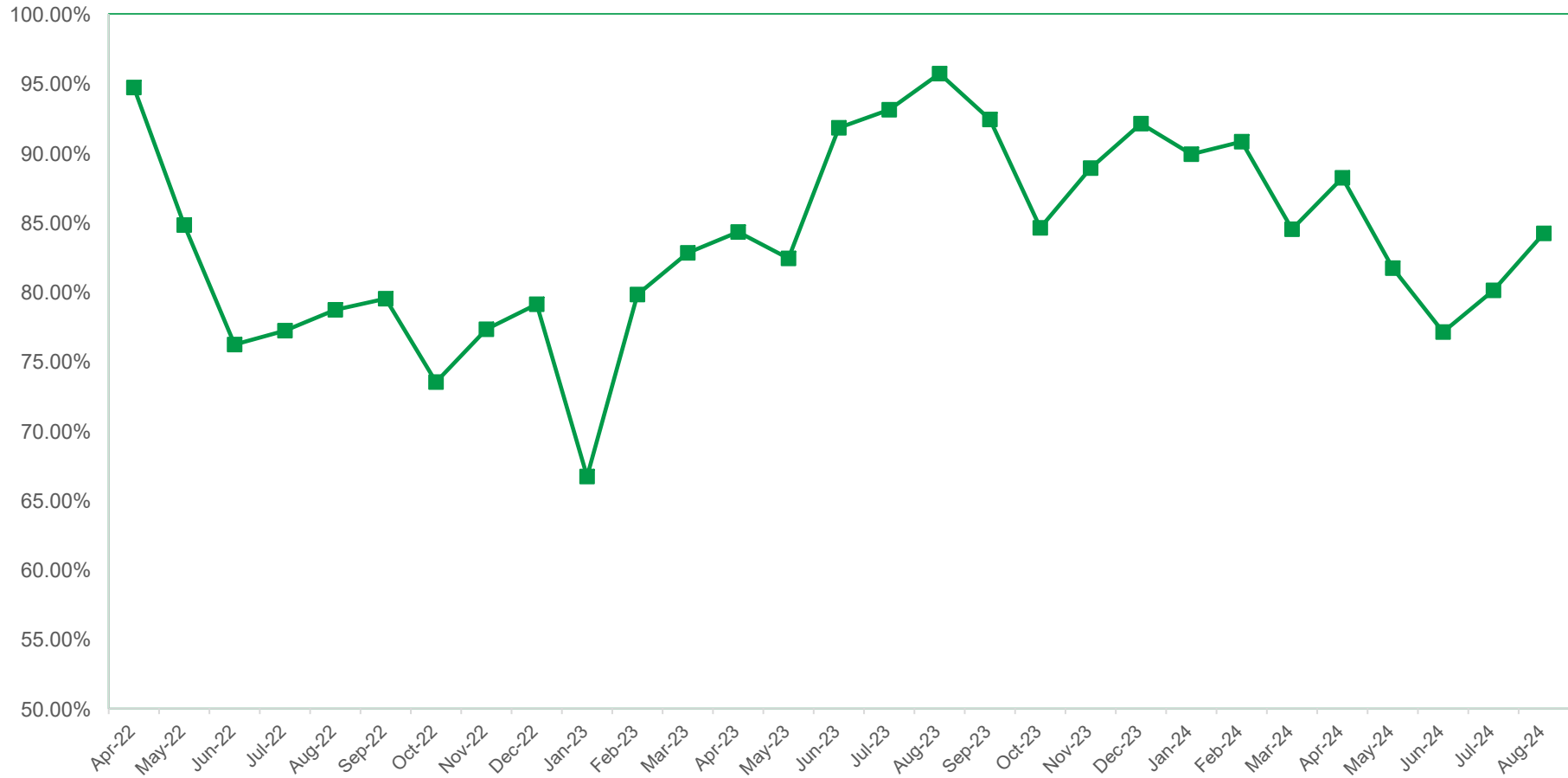

FIRST LINE FIX BY THE SERVICE DESK

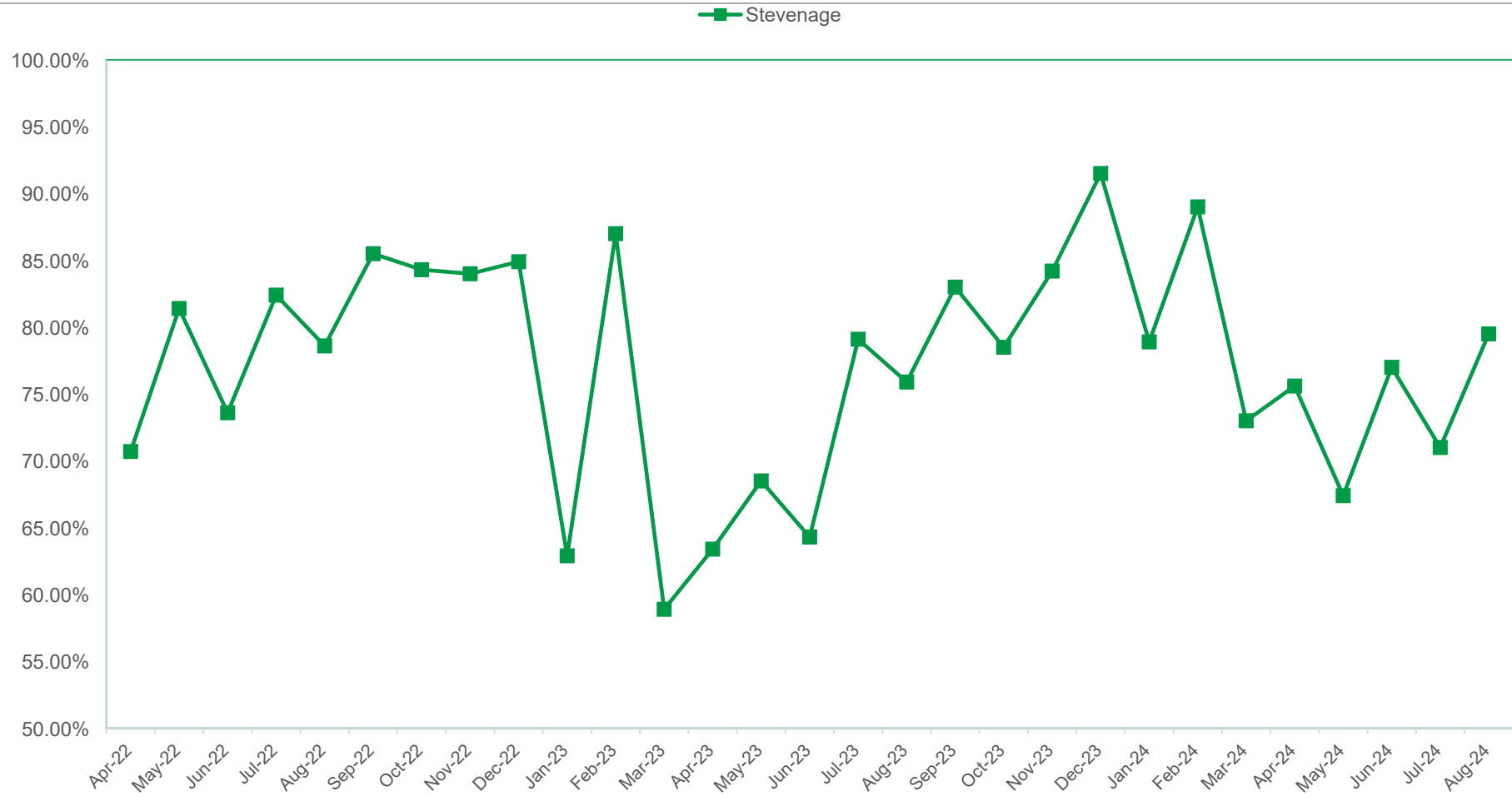

Number of Service Desk Calls

	Number Calls Logged	
	Per Day	Per hour
Apr-22	73	7.3
May-22	73	7.3
Jun-22	70	7.0
Jul-22	65	6.5
Aug-22	65	6.5
Sep-22	76	7.6
Oct-22	85	8.5
Nov-22	63	6.3
Dec-22	59	5.9
Jan-23	65	6.5
Feb-23	54	5.4
Mar-23	42	4.2
Apr-23	48	4.8
May-23	48	4.8
Jun-23	50	5.0
Jul-23	72	7.2
Aug-23	68	6.8
Sep-23	68	6.8
Oct-23	61	6.1
Nov-23	62	6.2
Dec-23	48	4.8
Jan-24	48	4.8
Feb-24	59	5.9
Mar-24	49	4.9
Apr-24	47	4.7
May-24	46	4.6
Jun-24	47	4.7
Jul-24	43	4.3
Aug-24	39	3.9
Sep-24	0	0.0

Any Questions

